

STRADDLES, A STRING-LINE INTERSECTION OF THE MONUMENT INTERSECT POSITION AND SET PK NAILS.

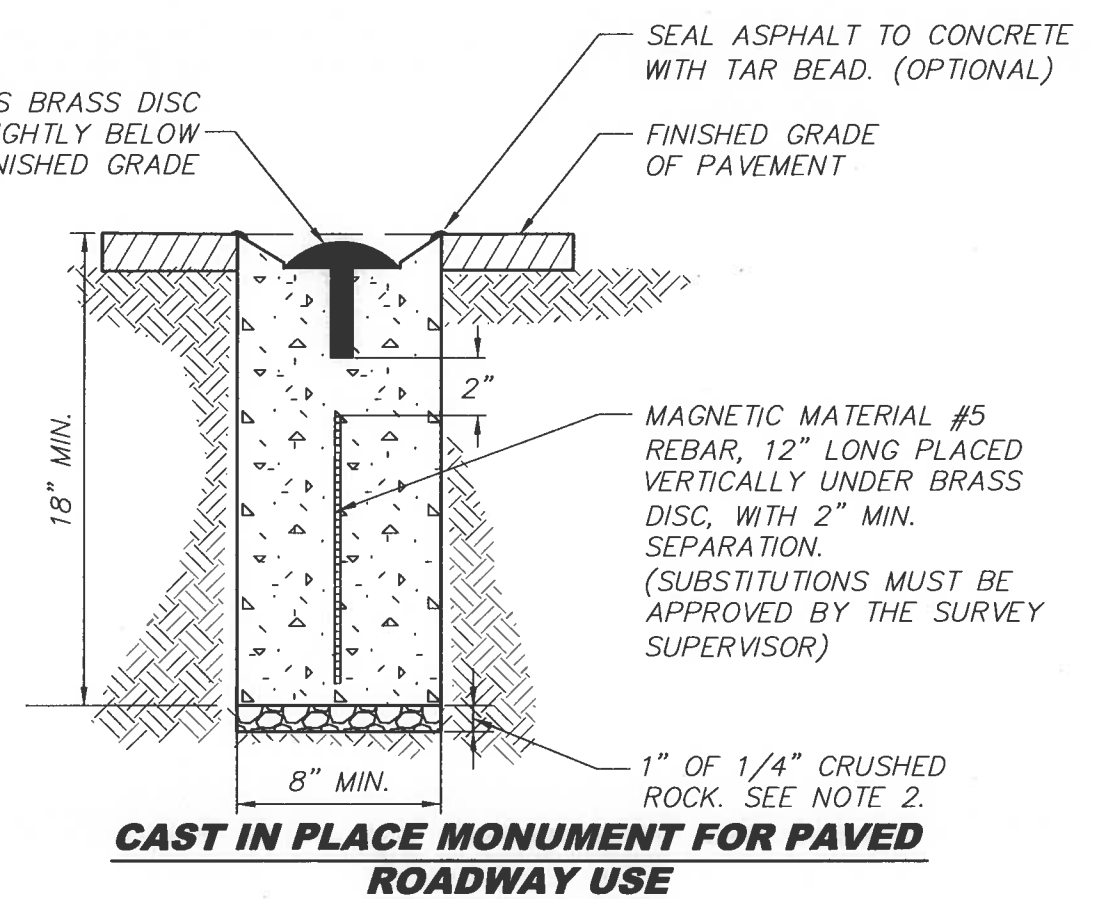
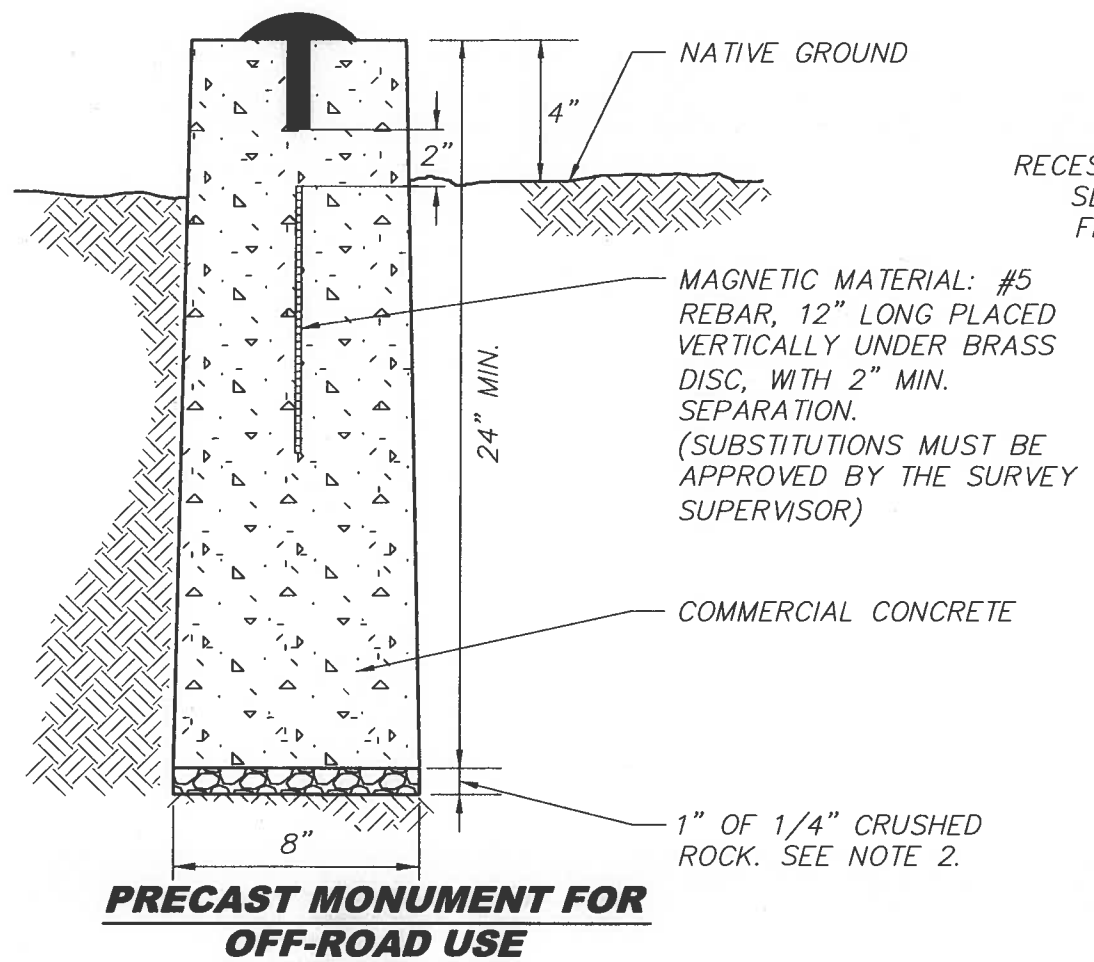

**NOTES:**

- 1) THE HOLE FOR THE MONUMENT SHALL BE CUT AFTER THE NEW PAVEMENT HAS BEEN CONSTRUCTED. THE UPPER 6" OF THE MONUMENT ENCASEMENT SHALL BE SHAPED TO A TRUE DIAMETER OF 8". THE BRASS DISC WILL SET DURING THE PLACEMENT OF THE CONCRETE.
- 2) MONUMENT CORE MATERIAL SHALL MEET OR EXCEED "RAPID SET NON-SHRINK, NON-METALLIC GROUT" OR APPROVED EQUAL MEETING ASTM 621. THE HOLE SHALL BE CORED TO 19" MIN. DEPTH. ALL LOOSE MATERIAL SHALL BE REMOVED FROM THE BOTTOM OF THE HOLE. THE CONCRETE SHALL BE PLACED ON A 1" (NOMINAL) LAYER OF 1/4 INCH CRUSHED ROCK OVER FIRM UNDISTURBED EARTH. THE TOP OF THE CONCRETE SHALL BE TROWELED SMOOTH AND THE BRASS DISC SHALL BE CENTERED AND SLIGHTLY BELOW GRADE TO PREVENT DAMAGE. THE REBAR SHALL BE CENTERED BENEATH THE BRASS DISC USING THE STRADDLES. APPROVED MAGNETIZED MATERIALS MAY BE EPOXIED TO THE UNDERSIDE OF THE BRASS DISC.
- 3) BRASS DISC SHALL BE MARKED BY AN "X" AT THE INTERSECT LOCATION, AND IDENTIFIED, AS REQUIRED BY RCW 58.09.120.
- 4) THE REQUIREMENT OF WAC 332-120 SHALL BE MET FOR THE REMOVAL OR DESTRUCTION OF A SURVEY MONUMENT.

(NOT TO SCALE)



**Pierce County**

Public Works and Utilities  
 Office of the County Engineer  
 Tacoma Mall Office Building  
 4301 South Pine Street, Suite 446  
 Tacoma, Washington 98409-7207  
 An APWA Accredited Agency



**BRIAN D. STACY, P.E.**  
**COUNTY ENGINEER**

3-20-12 Office of the County Engineer

**PIERCE COUNTY  
 STANDARD  
 MONUMENTS**

**PC.H1**