

NOTES:

- 1) SERVICE CABINET TO BE INSTALLED ON HINGED SIDE OF CONTROLLER CABINET (CONTROLLER CABINET DOOR TO OPEN TOWARD SERVICE CABINET).
- 2) 3/8" PLASTIC DRAIN TUBE TO BE PROVIDED FROM BASE OF EACH CABINET TO TOP OF FOUNDATION BASE AT BACK OF PEDESTAL.
- 3) DIMENSIONS TO SUIT CABINETS; CONTRACTOR SHALL VERIFY ACTUAL CABINET MEASUREMENTS PRIOR TO FORMING FOUNDATION PEDESTAL.
- 4) PAD SHALL HAVE A BRUSHED FINISH; THE PEDESTAL TOP SHALL HAVE A SMOOTH, TROWEL FINISH.

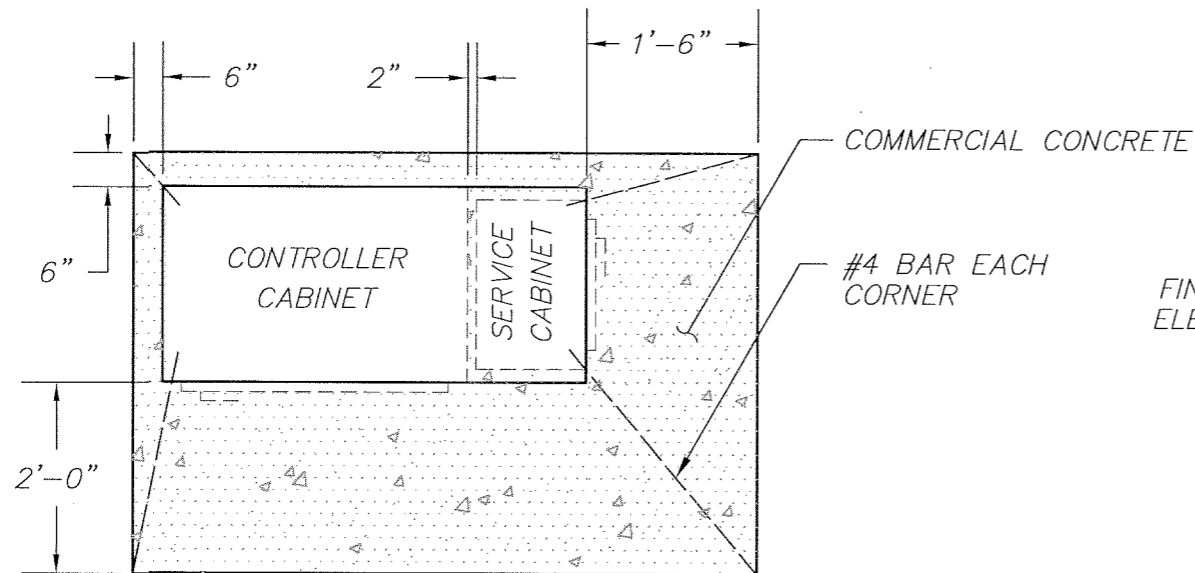

PLAN VIEW

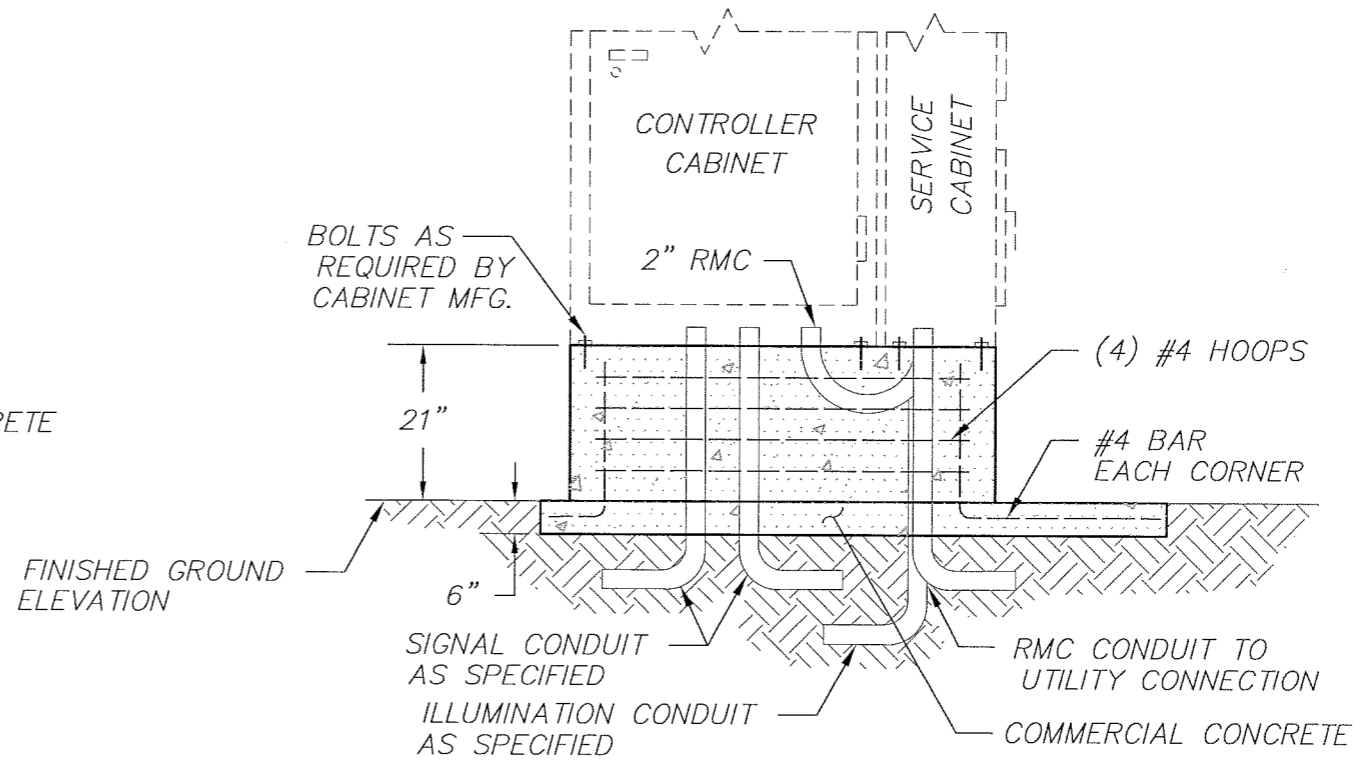

ELEVATION

(NOT TO SCALE)



Pierce County

Department of Public Works and Utilities
Transportation Services
2401 South 35th Street Room 150
Tacoma, Washington 98409-7485

DATE	REVISIONS	APPROVED	DRAWN
01-21-03	CORRECTED NOTE 3	<i>[Signature]</i>	PPS
4-11-01	REVISED NOTE 3, ADDED NOTE 4	<i>[Signature]</i>	CAB
	REVISED TITLE NAME		



THOMAS G. BALLARD, P.E.
COUNTY ENGINEER

[Signature]
MAY 1, 1997
Office of County Engineer

**COMBINED
CONTROLLER AND
SERVICE CABINET
PEDESTAL**

PC.J2.3